

# SPEEDWAY

## CT-90

### Semi-automatic table top capper

The Speedway CT90 semi-automatic cap tightener is a unique machine that handles glass, plastic or metal containers to reliably and accurately tighten caps for manual applications. It will accommodate any continuous thread cap (including child proof).

The universal bottle guide accurately centers round, square, rectangular, and many odd shaped containers. A multi-disc slip clutch provides reliable torque.

The CT90 is air operated and bottle sensing is provided for ease of operation. Change over from one container to another can be accomplished in minutes. Cycle speeds of 30 containers per minute can be achieved.



Manufactured in Canada by:  
**Speedway Packaging Machinery Inc.**  
[www.spmi.ca](http://www.spmi.ca)

# CT-90

## SEMI AUTOMATIC CAPPER

### Specifications

Air Consumption	1.5 c.f.m. at 90 p.s.i.
Cap type	Continuous thread All types including child proof
Cap Size	Up to 5" in diameter
Container Size	Up to 6" in diameter Up to 13" high
Chuck Size	1/2" - 5 1/2" in diameter
Optional	Sliding base plate for large bottles
Shipping Weight	48 lbs.

### Material

Stainless steel and aluminum construction

### Dimensions

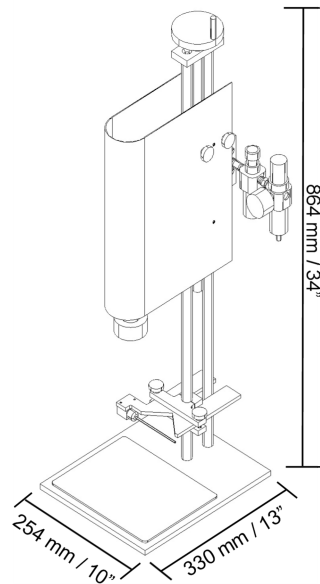

## The CT-90 Semi Automatic Capper has powerful features to meet production needs!!!

- ◆ Simple design and rugged construction will deliver years of reliable service.
- ◆ Simple operation.
- ◆ Easy and fast adjustment for bottle changeovers.
- ◆ Can be adapted for a wide variety of bottles allowing smooth production runs and no hassles for high efficiency.
- ◆ Air operated—no need for electricity.
- ◆ Its aesthetic outline and small footprint contributes to its versatility.
- ◆ Adjustable down force.
- ◆ Variety of chucks and liners available.
- ◆ The CT90 can be used as a stand alone or integrated into a semi-automatic machine with a conveyor for a faster automated line. Ask for information on a CT-90 CA.
- ◆ The CT90 is the best machine in terms of cost and performance.

### Manufactured by:

### **SPEEDWAY PACKAGING MACHINERY INC.**

Unit 4-5, 50 West Wilmot St.  
Richmond Hill, ON  
L4B 1M5  
(905) 888-5344