

SPEEDWAY

SPM-563 Semi-Automatic Case Erector & Pack Station

Side Belt Drive

Features:

The **SPM-563P** allows one person to form, pack and seal cartons in one operation. The operator opens the flat carton and places it into the erector. The machine folds the bottom flaps ready for packing. After packing, the operator presses the footswitch or pushbutton. The machine automatically pushes the carton into a case sealer, saving time and labour costs.

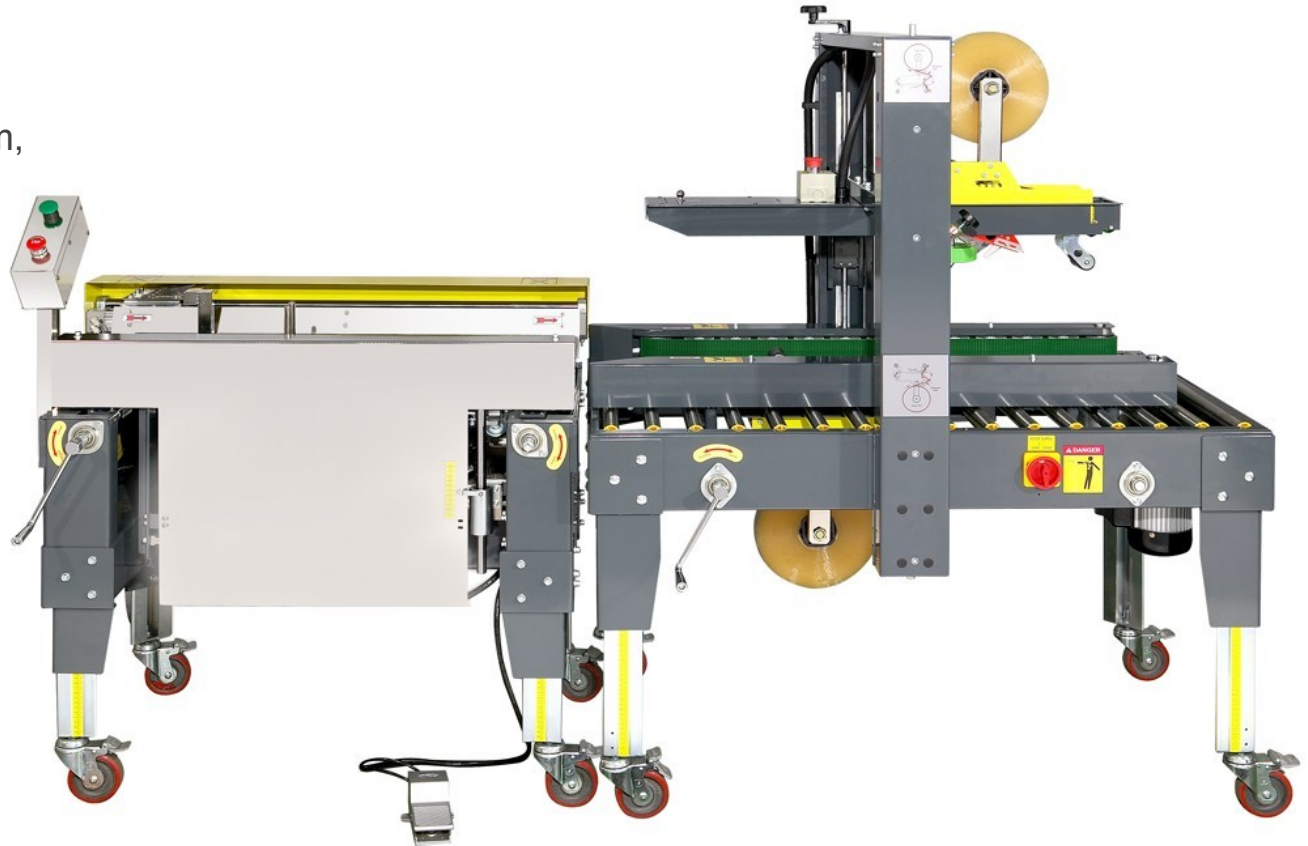

Shown with optional
SPM-553S Case Sealer



Speedway Packaging Machinery

www.spmi.ca

Manufactured in Taiwan

SPM-563S Semi-Automatic Carton Erector and Pack Station with Push Device

Specifications

Pneumatic operation	90 PSI
Power	N/A
Folding Size	L : 250mm - 650mm W : 200mm - 400mm H: 100mm - 500mm
Machine Weight	N.W. 182kg / 400 lbs G.W. 215 kg / 473 lbs
Machine Loading Weight	20kg / 44 lbs

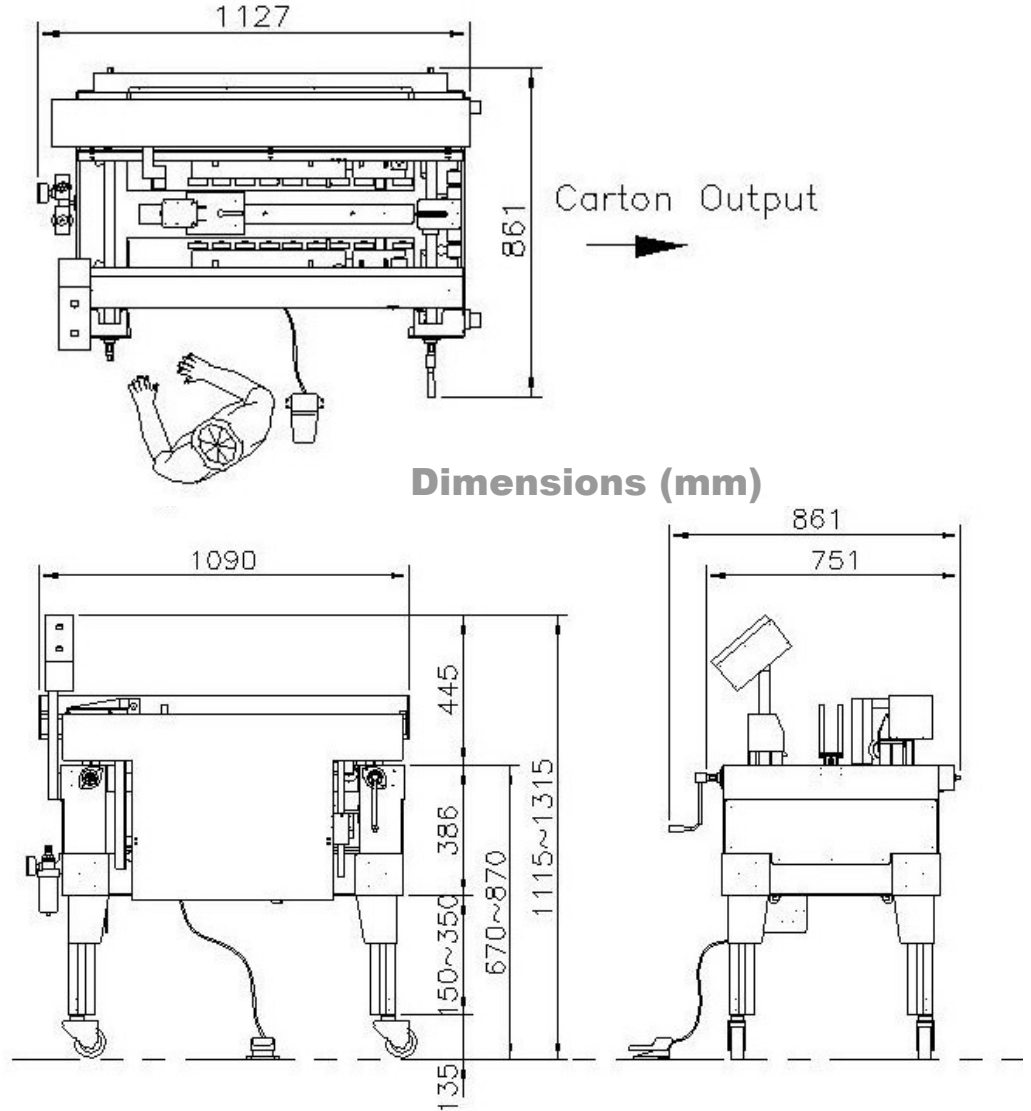

Distributed by:

Speedway Packaging Machinery
 50 West Wilmot St., Unit 4-5, Richmond Hill, ON L4B 1M5
 (905) 888-5344 www.spmi.ca

Specifications are subject to change without notice-

Manufactured in Taiwan